

DEPARTMENT OF THE ARMY TECHNICAL MANUAL

---

BEAM, HOISTING  
LIQUID GAS TANK, M1

---

*HEADQUARTERS, DEPARTMENT OF THE ARMY*

*JULY 1957*

**BEAM, HOISTING, LIQUID GAS TANK, M1**

	Paragraph	Page
Scope .....	1	2
Appendixes .....	2	2
Record and report forms .....	3	2
Use .....	4	2
Description .....	5	2
Operating instruction .....	6	2
Operator maintenance .....	7	2
Organizational maintenance .....	8	2
Shipment and limited storage .....	9	3
APPENDIX I. REFERENCES.....		4
II. MAINTENANCE ALLOCATION CHART 5.....		5

TAGO 672A - July 440465\* - 57

## 1. Scope

This manual describes the M1 liquid gas hoisting beam and provides instructions for its operation and maintenance.

## 2. Appendixes

Appendix I contains a list of current referent Appendix II contains the maintenance allocation chart.

### NOTE

For repair parts, see TM 3-662-15P.

## 3. Record and Report Form

Forms listed and described below will be used in connection with the equipment.

a. *DA Form 468 (Unsatisfactory Equipment Report)*. This form is used for reporting manufacturing, design, or operational defects in equipment with a view to correcting such defects. It is also used for recommending modifications of materiel.

b. *DD Form 6 (Report of Damaged or Improper Shipment)*. This form is used for reporting damages incurred in shipment.

## 4. Use

The M1 liquid gas tank hoisting beam (fig. 1) provides a means for attaching a hoist to a 1-ton container.

## 5. Description

The hoisting beam is 81 inches long and weighs 150 pounds. It consists of two structural steel channels with hoist hooks (9, fig. 2) pivoted at the ends, and a hoisting adapter (7) between them at the center. The channels, separated by spacers (6), are bolted together to form the hoisting beam. Each hook is pivoted on a stud (10) which is bolted to the two channels. A straight pin (11) at each end of the beam locks each hook against the rim of a 1-ton container while the container is being hoisted.

## 6. Operating Instructions

a. *Service upon Receipt of Equipment*. Unpack the hoisting beam from its wood packing case and inspect for missing or damaged parts. Tighten loose cap screws and be sure the hooks pivot easily on the studs.

b. *Operation*.

- (1) *Connecting the hoisting beam*. Hook hoisting adapter to hook on hoist and lower beam until it rests on container. Clamp hooks over rims of container. It

may be necessary to push the hooks upward into the space between the channels until the projections on the hooks can pass the pins. Raise beam by operating hoist. Raising beam will move hooks until weight of container is carried by studs, and pins lock hooks in place.

- (2) *Disconnecting the hoisting beam*. Lower 1-ton container to a support and lower beam until it rest on container. Unclamp hooks from rims of container by moving them outward. It may be necessary to push the hooks upward into the space between the channels while moving them to let the projections on the hooks pass the pins. When hooks are free, lower beam to support and disconnect adapter from hoist.

## 7. Operator Maintenance

a. *Preventative Maintenance Services*. Inspect the beam before and after operation for damage to the hoisting adapter (7, fig. 2), the hoist hooks (9), the channels (8), and other parts. Clean any dirt from the unit before using. Do not use a damaged beam, but replace the entire unit. Turn in any beam in need of repair or painting to organizational maintenance personnel.

b. *Lubrication*. Lubricate at least once a month or as required. Apply chain-wire rope-exposed gear lubricating oil (CW) to hoist hooks (9), studs (10), and straight pins (11).

## 8. Organizational Maintenance

a. *Repair*. Replace all damaged parts except the channels (8, fig. 2). If channels can no longer be used, the entire hoisting beam should be turned in for salvage. To replace parts, disassemble and assemble the beam in the following manner.

(1) *Disassembly*.

- (a) Remove 6 cap screws (4 and 5), 6 nuts (12 and 13), and 4 spacers (6).
- (b) Remove 4 nuts (2), 4 flat washers (3), and 4 cotter pins (1). The straight pins (11), the studs (10), the hoist hooks (9), and the hoisting adapter (7) can now be removed.

(2) *Assembly*. After replacing damaged parts, assemble the beam in reverse order of disassembly.

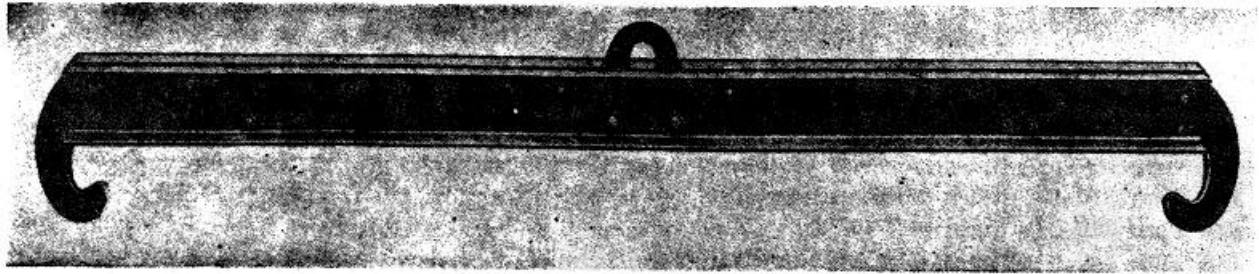
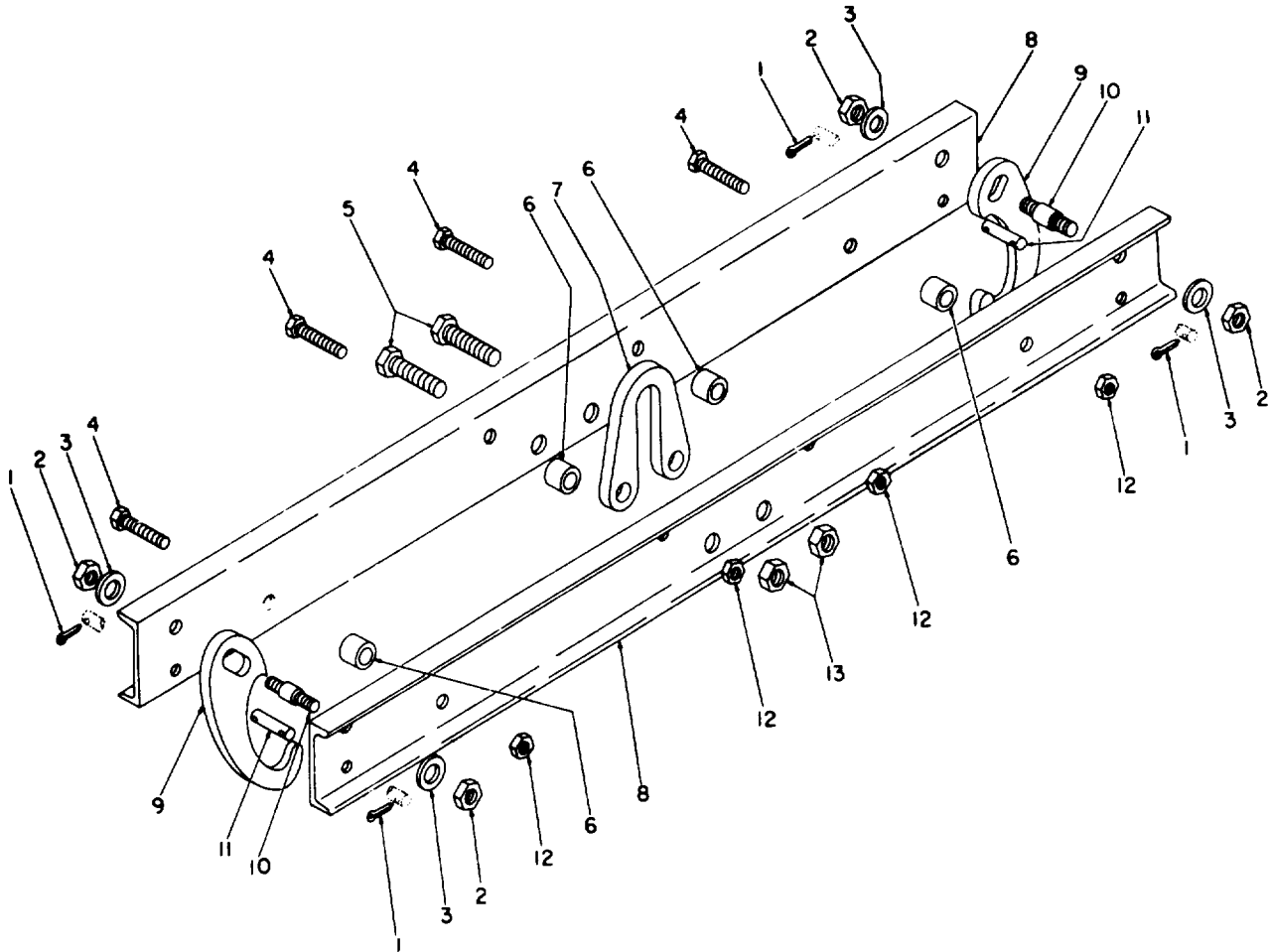

Figure 1. M1 liquid gas tank hoisting beam.



- |   |               |    |                  |
|---|---------------|----|------------------|
| 1 | Cotter pin    | 7  | Hoisting adapter |
| 2 | Nut           | 8  | Channel          |
| 3 | Flat washer   | 9  | Hoist hook       |
| 4 | Cap screw     | 10 | Stud             |
| 5 | Cap screw     | 11 | Straight pin     |
| 6 | Sleeve spacer | 12 | Nut              |
|   |               | 13 | Nut              |

Figure 2. Components of M1 liquid gas tank hoisting beam.

*b. Painting.* Repaint the beam with olive-drab enamel when necessary. Instructions for painting and materials to be used are given in TM 9-2851.

## 9. Shipment and Limited Storage

*a. Shipment.* Perform preventive maintenance TAGO 672A

services (par. 7a), lubricate, and pack the hoisting beam for shipment in a wood packing box. When packed for shipment, the beam weighs approximately 190 pounds.

*b. Limited Storage.* Prepare the beam as for shipment (a above), and store it in a dry place.

## APPENDIX I

### REFERENCES

---

DA Pam 108-1	Index of Army Motion Pictures, Filmstrips, Slides and Phono-Recordings..
DA Pam 310-2	Index of Blank Forms.
DA Pam 310-3	Index of Training Publications.
DA Pam 310-4	Index of Technical Manuals, Technical Regulations, Technical Bulletins, Supply Bulletins, Lubrication Orders, and Modification Work Orders.
SR 320-5-1	Dictionary of United States Army Terms.
AR 320-50	Authorized Abbreviations.
FM 21-5	Military Training.
FM 21-6	Techniques of Military Instruction.
FM 21-30	Military Symbols.
TM 9-2851	Painting Instructions for Field Use.

## APPENDIX II

### MAINTENANCE ALLOCATION CHART

FOR

### BEAM, HOISTING, LIQUID GAS TANK, M1

15 May 1957

#### 1. Purpose

The purpose of this appendix is to allocate maintenance functions which can be performed on the M1 liquid gas tank hoisting beam and its components.

#### 2. Scope

This appendix contains a tabulation of the functional groups, assemblies, subassemblies, and parts on which maintenance can be performed; a tabulation of applicable maintenance functions; and an indication of the lowest echelon at which each maintenance function is authorized.

#### 3. Use

Determine from the Maintenance Allocation Chart the echelon that is authorized to perform the required maintenance function. Refer to paragraphs 7 and 8 for instructions in performing the authorized maintenance function.

#### 4. Explanation of Columns

*a. Reference Numbers.* The first column lists reference numbers which identify components with the parent assembly. Reference numbers are assigned in multiples of 100 in sequence to assemblies listed in the second column, beginning with reference number 100 for the first assembly, 200 for the second assembly, and so on. Subassemblies of the first assembly are numbered in sequence from 101 to 199; subassemblies of the second assembly, 201 to 299; etc. Parts of subassemblies are numbered in sequence by a decimal following the number of the component. For example, the third maintainable part of the subassembly numbered 102 would be numbered 102.3.

*b. Components and Maintenance Functions.* The second column lists functional groups, assemblies, subassemblies, and parts on which maintenance can be performed, and the maintenance function which is authorized to be performed on each.

*c. Maintenance Echelon.* An X opposite the prescribed maintenance function indicates the lowest echelon authorized to perform the maintenance.

*d. Remarks.* The last column is used for special instructions.

#### 5. Definitions

- REPLACE** To substitute serviceable assemblies, subassemblies and parts for unserviceable components.
- SERVICE** To clean, to preserve, and to replenish fuel and lubricants.
- SYMBOL X** The symbol X placed in the appropriate column indicates the echelon responsible for performing the particular maintenance function, but does not necessarily indicate that repair parts will be stocked at that level. Echelons higher than the echelon marked by X are authorized to perform the indicated function.

#### **MAINTENANCE ALLOCATION CHART FOR Beam, locating, Liquid Gas Tank, M1**

Refer ence - No.	Component and main- tenance	Maintenance echelon				Remarks
		1st	2d	3d and 4th	5th	
100	Adapter: Replace	----	X	----	----	-----
200	Hooks: Service	X		----	----	-----
	Replace	----	X	----	----	-----
300	Pins: Service	X		----	----	-----
	Replace	----	X	----	----	-----
400	Spacers: Replace	----	X	----	----	-----
500	Studs Service	X		----	----	-----
	Replace	----	X	----	----	-----

By Order of *Wilber M. Brucker*, Secretary of The Army:

MAXWELL, D. TAYLOR,  
*General, United States Army,*  
*Chief of Staff.*

Official:

HERBERT M. JONES,  
*Major General, United States Army,*  
*The Adjutant General.*

Distribution:

*Active Army:*

CNGB	USA Cml Cen & CmlICMatCom
Technical Svc, DA	CmlICEnCom
Technical Svc Bd	CmlICTngCom
Army Maint Bd	MDW
USA Arty Bd	Armies
USA Armor Bd	Corps
USA Armor Bd Test Sec	Div
USA Inf Bd	Ft & Camps
USA Air Def Bd	USMA
USA Air Def Bd Test Sec	Svc Colleges
USA Abn & Elct Bd	Br Svc Sch
USA Avn Bd	PMST Sr Div Cml Units
USCONARC	Gen Depots
USARADCOM	Cml Sec, Gen Depots
OS Maj Comd	Cml Depots
OS Base Comd	Port of Emb (OS)
Log Comd	Trans Terminal Comd

Army Terminals  
OS Sup Agencies  
PG  
Cml Arsenals  
Mil Dist  
Cml Proc Dist  
Units organized under following  
TOE's:  
3-32 Hq & Hq Det, Cml Gp  
Field, Army or COMZ  
3-36 Hq & Hq Det, Cml Bn,  
Svc, Army or COMZ  
3-47 Cml Maint Co  
3-57 Cml Depot Co  
3-117 Cml Depot Co, COMZ  
3-500 (AA-AC) Cml Svc Org

*NG:* State AG; units - same as Active Army.

*USAR:* None.

For explanation of abbreviations used, see AR 320-50.

☆ U.S. GOVERNMENT PRINTING OFFICE: 1994 - 300-421/82162

TAGO 672A

PIN : 024113-000

RECOMMENDED CHANGES TO EQUIPMENT TECHNICAL PUBLICATIONS

 <p style="font-size: small; margin: 0;"><i>THEN...JOT DOWN THE DOPE ABOUT IT ON THIS FORM. CAREFULLY TEAR IT OUT, FOLD IT AND DROP IT IN THE MAIL.</i></p>		SOMETHING WRONG WITH PUBLICATION	
		FROM: (PRINT YOUR UNIT'S COMPLETE ADDRESS)	
		DATE SENT	
PUBLICATION NUMBER		PUBLICATION DATE	PUBLICATION TITLE
IN THIS SPACE, TELL WHAT IS WRONG AND WHAT SHOULD BE DONE ABOUT IT.			
BE EXACT PIN-POINT WHERE IT IS			
PAGE NO.	PARA-GRAPH	FIGURE NO.	TABLE NO.
PRINTED NAME, GRADE OR TITLE AND TELEPHONE NUMBER		SIGN HERE	



## The Metric System and Equivalents

### *Linear Measure*

1 centimeter = 10 millimeters = .39 inch  
 1 decimeter = 10 centimeters = 3.94 inches  
 1 meter = 10 decimeters = 39.37 inches  
 1 dekameter = 10 meters = 32.8 feet  
 1 hectometer = 10 dekameters = 328.08 feet  
 1 kilometer = 10 hectometers = 3,280.8 feet

### *Weights*

1 centigram = 10 milligrams = .15 grain  
 1 decigram = 10 centigrams = 1.54 grains  
 1 gram = 10 decigrams = .035 ounce  
 1 decagram = 10 grams = .35 ounce  
 1 hectogram = 10 decagrams = 3.52 ounces  
 1 kilogram = 10 hectograms = 2.2 pounds  
 1 quintal = 100 kilograms = 220.46 pounds  
 1 metric ton = 10 quintals = 1.1 short tons

### *Liquid Measure*

1 centiliter = 10 milliliters = .34 fl. ounce  
 1 deciliter = 10 centiliters = 3.38 fl. ounces  
 1 liter = 10 deciliters = 33.81 fl. ounces  
 1 dekaliter = 10 liters = 2.64 gallons  
 1 hectoliter = 10 dekaliters = 26.42 gallons  
 1 kiloliter = 10 hectoliters = 264.18 gallons

### *Square Measure*

1 sq. centimeter = 100 sq. millimeters = .155 sq. inch  
 1 sq. decimeter = 100 sq. centimeters = 15.5 sq. inches  
 1 sq. meter (centare) = 100 sq. decimeters = 10.76 sq. feet  
 1 sq. dekameter (are) = 100 sq. meters = 1,076.4 sq. feet  
 1 sq. hectometer (hectare) = 100 sq. dekameters = 2.47 acres  
 1 sq. kilometer = 100 sq. hectometers = .386 sq. mile

### *Cubic Measure*

1 cu. centimeter = 1000 cu. millimeters = .06 cu. inch  
 1 cu. decimeter = 1000 cu. centimeters = 61.02 cu. inches  
 1 cu. meter = 1000 cu. decimeters = 35.31 cu. feet

## Approximate Conversion Factors

<i>To change</i>	<i>To</i>	<i>Multiply by</i>	<i>To change</i>	<i>To</i>	<i>Multiply by</i>
inches	centimeters	2.540	ounce-inches	Newton-meters	.007062
feet	meters	.305	centimeters	inches	.394
yards	meters	.914	meters	feet	3.280
miles	kilometers	1.609	meters	yards	1.094
square inches	square centimeters	6.451	kilometers	miles	.621
square feet	square meters	.093	square centimeters	square inches	.155
square yards	square meters	.836	square meters	square feet	10.764
square miles	square kilometers	2.590	square meters	square yards	1.196
acres	square hectometers	.405	square kilometers	square miles	.386
cubic feet	cubic meters	.028	square hectometers	acres	2.471
cubic yards	cubic meters	.765	cubic meters	cubic feet	35.315
fluid ounces	milliliters	29.573	cubic meters	cubic yards	1.308
pints	liters	.473	milliliters	fluid ounces	.034
quarts	liters	.946	liters	pints	2.113
gallons	liters	3.785	liters	quarts	1.057
ounces	grams	28.349	liters	gallons	.264
pounds	kilograms	.454	grams	ounces	.035
short tons	metric tons	.907	kilograms	pounds	2.205
pound-feet	Newton-meters	1.356	metric tons	short tons	1.102
pound-inches	Newton-meters	.11296			

## Temperature (Exact)

°F	Fahrenheit temperature	5/9 (after subtracting 32)	Celsius temperature	°C
----	---------------------------	-------------------------------	------------------------	----

